

10GBASE-LR SFP+ 1310nm 10km DOM Transceiver

SFP-10GLR-31



Application

- 10GBASE-LR/LW 10G Ethernet
- 1200-SM-LL-L 10G Fibre Channel

Features

- Hot-pluggable SFP+ footprint
- Supports 9.95 to 10.5Gb/s bit rates
- Power dissipation < 1W
- RoHS-6 compliant (lead-free)
- Industrial temperature range : -40° C to 85° C
- Single 3.3V power supply
- Maximum link length of 10km
- Uncooled 1310nm DFB laser
- Receiver limiting electrical interface
- Duplex LC connector
- Built-in digital diagnostic functions

Description

10Gb/s Enhanced Small Form Factor Pluggable SFP+ transceivers are designed for use in 10-Gigabit Ethernet links up to 10km over Single Mode fiber. They are compliant with SFF-8431, SFF-8432 and IEEE 802.3ae 10GBASE-LR/LW, and 10G Fibre Channel 1200-SM-LL-L. Digital diagnostics functions are available via a 2-wire serial interface. The transceiver is a “limiting module”, i.e., it employs a limiting receiver. Host board designers using an EDC PHY IC should follow the IC manufacturer’s recommended settings for interoperating the host-

board EDC PHY with a limiting receiver SFP+ module. The optical transceiver is compliant per the RoHS Directive 2011/65/EU.

Product Specifications

I. General Specifications

Data Rate Specifications	Symbol	Min	Typ.	Max	Units	Ref.
Bit Rate	BR	3.144		11.3168	Gb/s	1
Bit Error Ratio	BER			10 ⁻¹²		2
Max. Supported Link Length	L MAX			40	km	1

Notes:

1. 10GBASE-LR, 10GBASE-LW, 1200-SM-LL-L 10GFC.
2. Tested with a 2³¹ – 1 PRBS.

II. Absolute Maximum Ratings

Parameter	Symbol	Min	Typ.	Max	Unit	Ref.
Maximum Supply Voltage	V _{CC}	-0.5		4.0	V	
Storage Temperature	T _S	-40		85	° C	
Case Operating Temperature	T _{OP}	-40		85	° C	
Relative Humidity	RH	0		85	%	1
Receiver Optical Damage Threshold	RxDamage	5			dBm	

Note:

Non-condensing.

III. Electrical Characteristics (TOP = 0 to 70 °C, VCC = 3.14 to 3.46 V)

Parameter	Symbol	Min	Typ.	Max	Unit	Ref.
Supply Voltage	V _{CC}	3.14	3.30	3.46	V	
Supply Current	I _{CC}		200	285	mA	
Transmitter						
Input differential impedance	R _{in}		100	120	Ω	1
Differential data input swing	V _{in,pp}	180		850	mVpp	
Transmit Disable Voltage	V _D	2	50	V _{CC}	V	
Transmit Enable Voltage	V _{EN}	V _{ee}		0.8	V	

Receiver

Differential data output swing	$V_{out,pp}$	300		850	mV	2,5
Output rise time and fall time	T_r, T_f	28			ps	3
LOS Fault	$V_{LOS\ fault}$	2		V_{cc}	V	4
LOS Normal	$V_{LOS\ norm}$	V_{ee}		0.8	V	4
Power Supply Noise Tolerance	V_{ccT}/V_{ccR}		Per SFF-8431 Rev 3.0		mVpp	

Notes:

1. Connected directly to TX data input pins. AC coupling from pins into laser driver IC.
2. Into 100 Ω differential termination.
3. 20 – 80%. Measured with Module Compliance Test Board and OMA test pattern. Use of four 1' s and four 0' s sequence in the PRBS 9 is an acceptable alternative.
4. LOS is an open collector output. Should be pulled up with 4.7k Ω – 10k Ω on the host board. Normal operation is logic 0; loss of signal is logic 1.
5. The transceiver is a “limiting module” , i.e., it employs a limiting receiver. Host board designers using an EDC PHY IC should follow the IC manufacturer' s recommended settings for interoperating the host-board EDC PHY with a limiting receiver SFP+ module.

IV. Optical Characteristics (TOP = -40 to 85 °C, VCC = 3.14 to 3.46 V)

Parameter	Symbol	Min	Typ.	Max	Unit	Note
Transmitter						
Optical Modulation Amplitude (OMA)	P_{OMA}	-5.2			dBm	
Average Launch Power	P_{AVE}	-8.2		+0.5	dBm	1
Optical Wavelength	λ	1260		1355	nm	
Side-Mode Suppression Ratio	SMSR	30			dB	
Optical Extinction Ratio	ER	3.5			dB	
Transmitter and Dispersion Penalty	TDP			3.2	dB	
Average Launch power when Tx is OFF	P_{OFF}			-30	dBm	
Tx Jitter	Txj	Per 802.3ae requirements				
Relative Intensity Noise	RIN			-128	dB/Hz	
Receiver						
Receiver Sensitivity (OMA) @ 10.3Gb/S	R_{SENS1}			-12.6	dBm	2
Receiver Sensitivity (OMA) @ 10.3Gb/s	R_{SENS2}			-10.3	dBm	3
Average Receiver Power	P_{AVE}	-14.4		+0.5	dBm	
Optical Center Wavelength	λ_C	1260		1600	nm	
Receiver Reflectance	Rrx			-12	dB	

LOS De-Assert	LOS De-Assert	LOS_D	-17				dBm
LOS Assert		LOS_A	-30				dBm
LOS Hysteresis			0.5				dB

Notes:

1. Average power figures are informative only, per IEEE 802.3ae.
2. Valid between 1260 and 1355 nm. Measured with worst ER; BER<10-12; 231- 1 PRBS.
3. Valid between 1260 and 1355 nm. Per IEEE 802.3ae.

V. Digital Diagnostic Specifications

10GBASE-LR SFP+ transceivers can be used in host systems that require either internally or externally calibrated digital diagnostics.

Parameter	Symbol	Min	Typ.	Max	Units	Ref.
-----------	--------	-----	------	-----	-------	------

Accuracy

Internally measured transceiver temperature	$\Delta DD_{Temperature}$			3	°C	
Internally measured transceiver supply voltage	$\Delta DD_{Voltage}$			3	%	
Measured TX bias current	ΔDD_{Bias}			10	%	1
Measured TX output power	$\Delta DD_{Tx-Power}$			2	dB	
Measured RX received average optical power	$\Delta DD_{Rx-Power}$			2	dB	

Dynamic Range for Rated Accuracy

Internally measured transceiver temperature	$DD_{Temperature}$	-40	85	°C	
Internally measured transceiver temperature	$DD_{Voltage}$	3.1	3.5	V	
Measured TX bias current	DD_{Bias}	10	90	mA	
Measured TX output power	$DD_{Tx-Power}$	-8.2	+0.5	dBm	
Measured RX received average optical power	$DD_{Rx-Powe}$	-14.2	+0.5	dBm	

Max Reporting Range

Internally measured transceiver temperature	$DD_{Temperature}$	-40	125	°C	
Internally measured transceiver supply voltage	$DD_{Voltage}$	2.8	4.0	V	
Measured TX bias current	DD_{Bias}	0	20	mA	
Measured TX output power	$DD_{Tx-Power}$	-10	+2	dBm	
Measured RX received average optical power	$DD_{Rx-Power}$	-22	+2	dBm	

Notes:

Accuracy of measured Tx bias current is 10% of the actual bias current from the laser driver to the laser.

VI. Pin Description

Pin	Symbol	Name/Description	Ref.
1	V_{EET}	Transmitter Ground	1
2	T_{FAULT}	Transmitter Fault	2
3	T_{DIS}	Transmitter Disable. Laser output disabled on high or open.	3
4	SDA	2-wire Serial Interface Data Line	2
5	SCL	2-wire Serial Interface Clock Line	2
6	MOD_ABS	Module Absent. Grounded within the module	2
7	RS0	Rate Select 0.	4
8	RX_LOS	Loss of Signal indication. Logic 0 indicates normal operation.	5
9	RS1	Rate Select 1.	4
10	V_{EER}	Receiver Ground	1
11	V_{EER}	Receiver Ground	1
12	RD-	Receiver Inverted DATA out. AC Coupled.	
13	RD+	Receiver Non-inverted DATA out. AC Coupled.	
14	V_{EER}	Receiver Ground	1
15	V_{CCR}	Receiver Power Supply	
16	V_{CCT}	Transmitter Power Supply	
17	V_{EET}	Transmitter Ground	1
18	TD+	Transmitter Non-Inverted DATA in. AC Coupled.	
19	TD-	Transmitter Inverted DATA in. AC Coupled.	
20	V_{EET}	Transmitter Ground	1

Notes:

1. Circuit ground is internally isolated from chassis ground.
2. TFAULT is an open collector/drain output, which should be pulled up with a 4.7k -10k Ohms resistor on the host board if intended for use. Pull up voltage should be between 2.0V to Vcc + 0.3V. A high output indicates a transmitter fault caused by either the TX bias current or the TX output power exceeding the preset alarm thresholds. A low output indicates normal operation. In the low state, the output is pulled to <0.8V.
3. Laser output disabled on TDIS >2.0V or open, enabled on TDIS <0.8V.
4. Internally pulled down per SFF-8431 Rev 2.0. See Sec. X for the logic table to use for the internal CDRs locking modes.
5. LOS is open collector output. Should be pulled up with 4.7kΩ -10kΩ on host board to a voltage between 2.0V and 3.6V. Logic 0 indicates normal operation; logic 1 indicates loss of signal.

VII. Mechanical Specifications

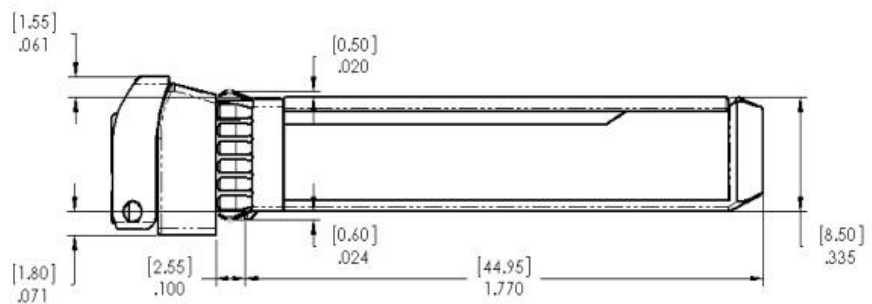
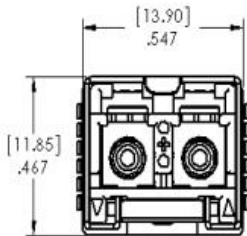
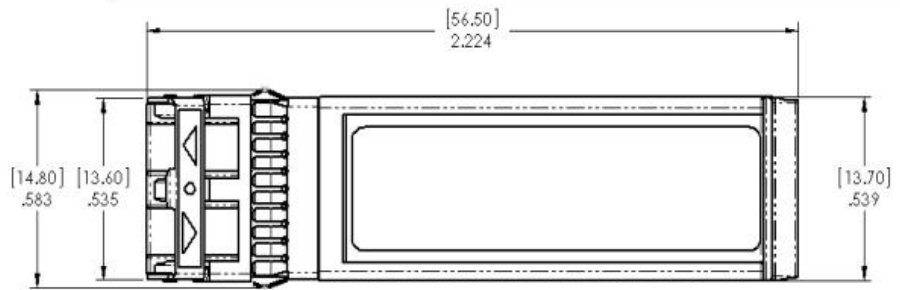

VIII. Host Board SFP+ Connector Recommendations

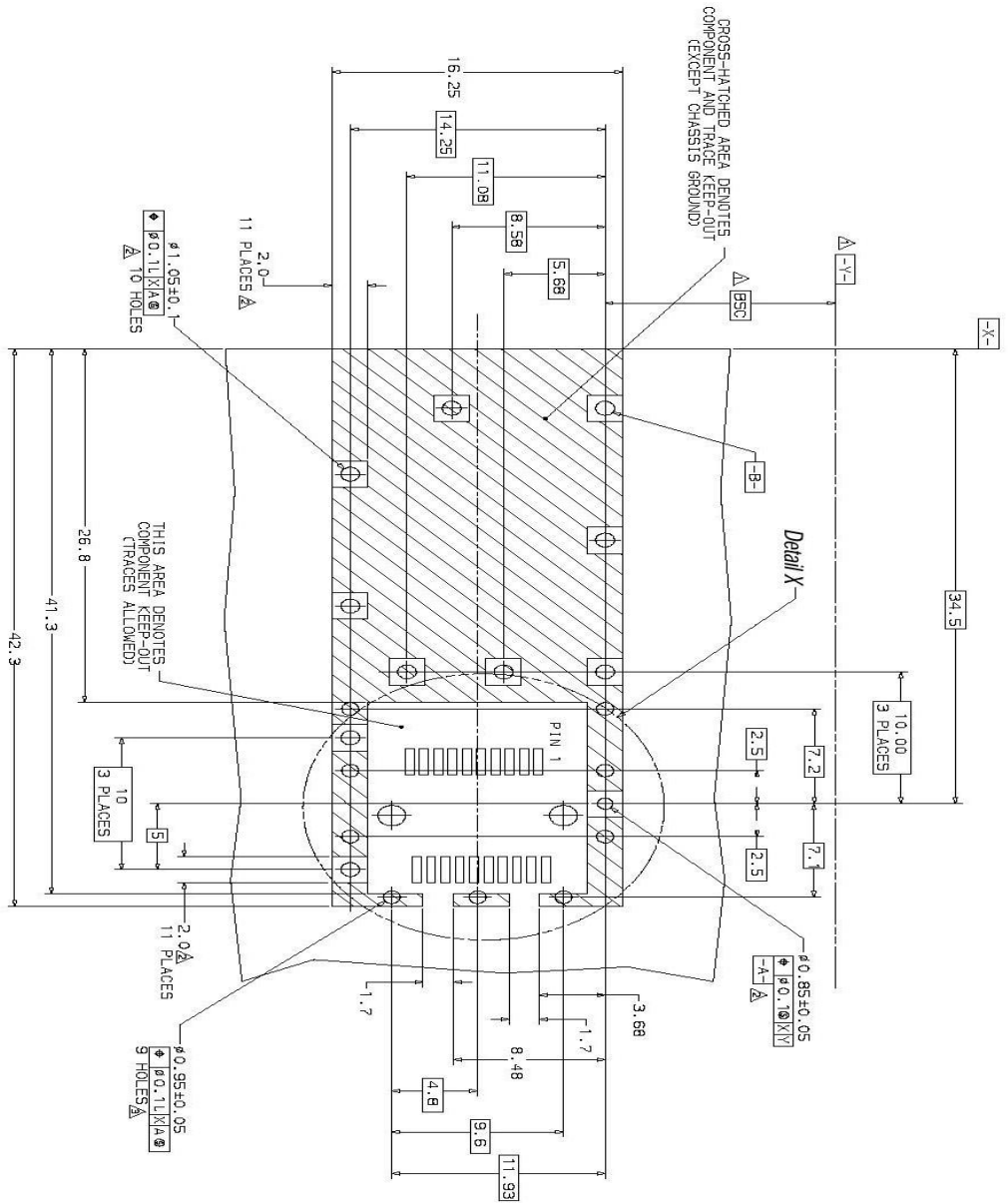

△ Datum and Basic Dimension Established by Customer

⊕ Pads and Vias are Chassis Ground, 11 Places

⊖ Through Holes are Unplated

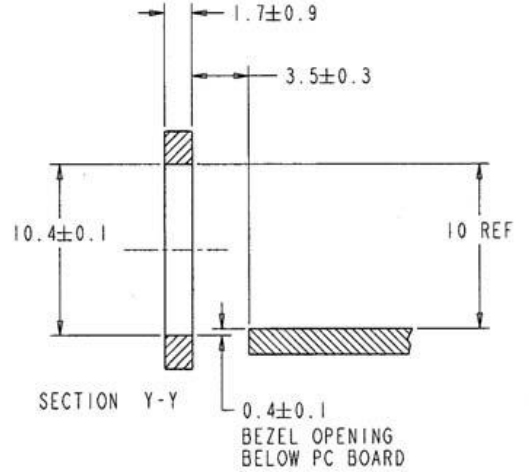
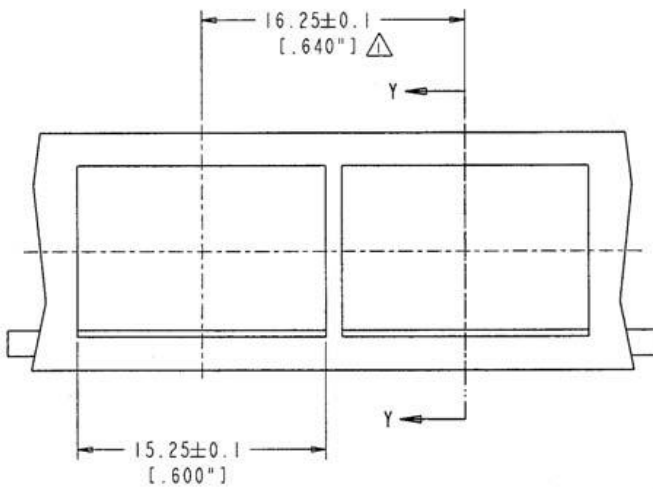
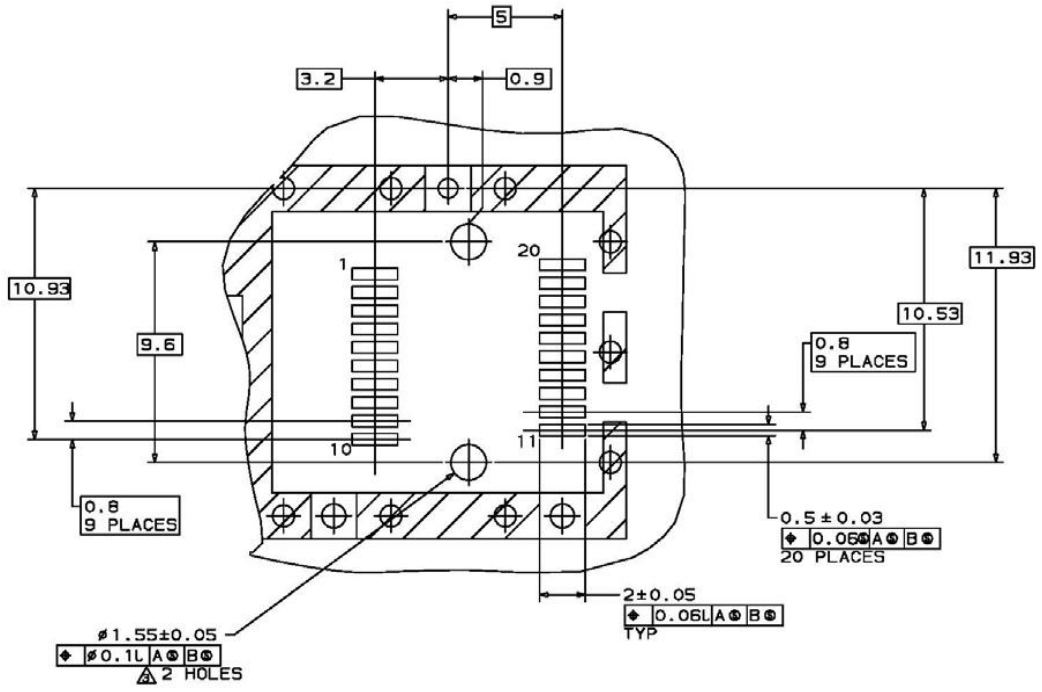

NOTES:

△ MINIMUM PITCH ILLUSTRATED, ENGLISH DIMENSIONS ARE FOR REFERENCE ONLY

2. NOT RECOMMENDED FOR PCI EXPANSION CARD APPLICATIONS

Test Center

FS.COM transceivers are tested to ensure connectivity and compatibility in our test center before shipped out. FS.COM test center is supported by a variety of mainstream original brand switches and groups of professional staff, helping our customers make the most efficient use of our products in their systems, network designs and deployments.

The original switches could be found nowhere but at FS.COM test center, eg: Juniper MX960 & EX 4300 series, Cisco Nexus 9396PX & Cisco ASR 9000 Series, HP 5900 Series & HP 5406R ZL2 V3(J9996A), Arista 7050S-64, Brocade ICX7750-26Q & ICX6610-48, Avaya VSP 7000 MDA 2, etc.



Cisco ASR 9000 Series(A9K-MPA-1X40GE)



ARISTA 7050S-64(DCS-7050S-64)

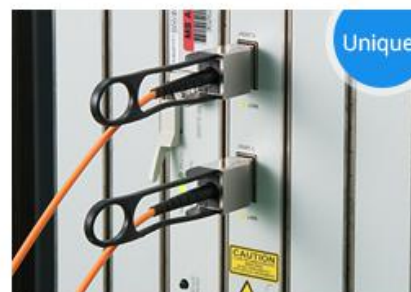

Juniper MX960



Brocade ICX 7750-26Q



Extreme Networks X670V VIM-40G4X



Mellanox M3601Q



Dell N4032F



HP 5406R ZL2 V3(J9996A)



AVAYA 7024XLS(7002QQ-MDA)

Test Assured Program

FS.COM truly understands the value of compatibility and interoperability to each optics. Every module FS.COM provides must run through programming and an extensive series of platform diagnostic tests to prove its performance and compatibility. In our test center, we care of every detail from staff to facilities—professionally trained staff, advanced test facilities and comprehensive original-brand switches, to ensure our customers to receive the optics with superior quality.



Our smart data system allows effective product management and quality control according to the unique serial number, properly tracking the order, shipment and every part.

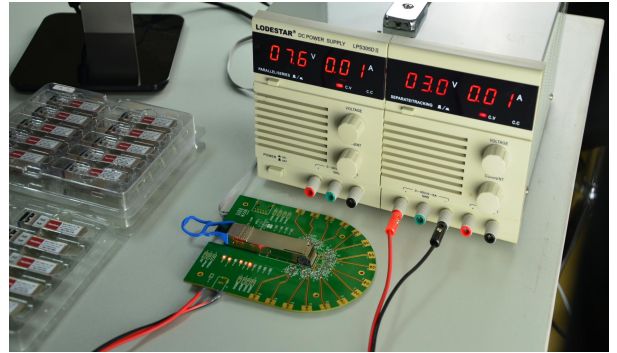

Our in-house coding facility programs all of our parts to standard OEM specs for compatibility on all major vendors and systems such as Cisco, Juniper, Brocade, HP, Dell, Arista and so on.



With a comprehensive line of original-brand switches, we can recreate an environment and test each optics in practical application to ensure quality and distance.



The last test assured step to ensure our products to be shipped with perfect package.

Order Information

Part Number	Description
SFP-10GSR-85	10GBASE-SR SFP+ 850nm 300m DOM Transceiver
SFP-10GLRM-31	10G SFP+ 1310nm 2km DOM Transceiver
SFP-10GLR-31	10GBASE-LR SFP+ 1310nm 10km DOM Transceiver
SFP-10GER-55	10GBASE-ER SFP+ 1550nm 40km DOM Transceiver
SFP-10GZR-55	10GBASE-ZR SFP+ 1550nm 80km DOM Transceiver
SFP-10GZRC-55	10G SFP+ 1550nm 100km DOM Transceiver
SFP-10GSR-85	Dual-Rate 1000BASE-SX and 10GBASE-SR SFP+ 850nm 300m DOM Transceiver
SFP-10GLR-31	Dual-Rate 1000BASE-LX and 10GBASE-LR SFP+ 1310nm 10km DOM Transceiver

Note:

10G SFP+ transceiver module is individually tested on corresponding equipment such as Cisco, Arista, Juniper, Dell, Brocade and other brands, and passes the monitoring of FS.COM intelligent quality control system.



 <https://www.fs.com>



All statements, technical information, and recommendations related to the products here are based upon information believed to be reliable or accurate. However, the accuracy or completeness thereof is not guaranteed, and no responsibility is assumed for any inaccuracies. Please contact FS for more information.